

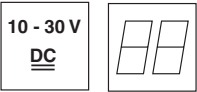

MA 4/MA 4D

Connector unit for BCL 21/22 and BCL 31/32



- May be used with BCL 21/22 and 31/32
- The integrated failure-safe parameter memory for the BCL data (EEPROM) permits exchanging the BCL without reconfiguration
- Integrated two-line display with 16 characters each (MA 4D only)
- Networking of several BCL 21 or BCL 31 via RS485 interface, hardware addressing in Leuze multiNetplus
- Additional RS232 service interface (9-pin sub D connector), operating mode switch service/standard operation
- Terminals for switching inputs and outputs including power supply and for looping through of the the RS 485 line (BCL 21/31)
- Rotary switch for address setting



Accessories:

(available separately)

- Bar code reader BCL 21/22 and BCL 31/32
- Cable KB 031-3000 for connecting the connector unit to the BCL 31/32

Dimensioned drawing

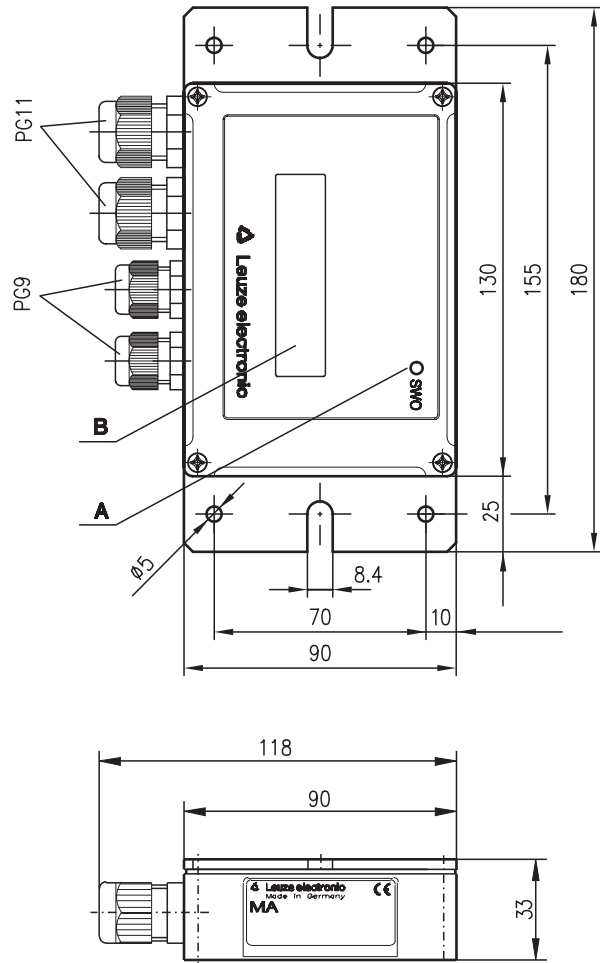

- A LED indicator
- B LCD indicator

Electrical Connection

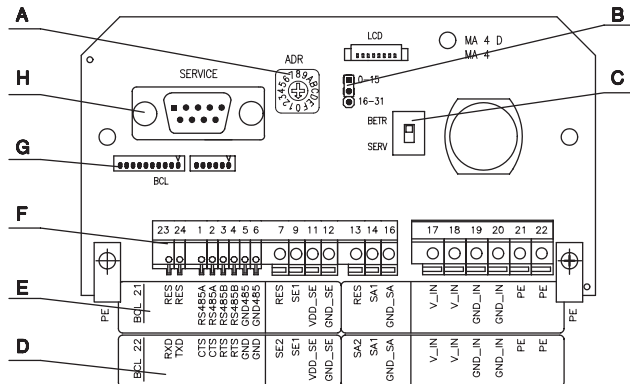

- A Setting of the device address
- B Setting of the device address
- C Service/operation switch
- D Attached label with terminal assign. for RS232
- E Attached label with terminal assign. for RS485
- F Terminal strip
- G Connection BCL
- H Service interface

We reserve the right to make changes • Ma4\_Ma4d\_01e.fm

## Specifications

	MA 4	MA 4D
<b>Electrical data</b>		
Operating voltage $U_B$	10 ... 30VDC	
Power consumption	0.2VA	
Switching input	12 ... 30VDC	
Switching output	$I_{max} = 100mA$ output voltage = operating voltage	
<b>Mechanical data</b>		
Housing	diecast aluminium	
Housing cover	sheet steel	
Dimensions	130 x 90 x 33mm (H x W x D)	
Weight	0.665 kg	0.672 kg
Connection type	cable with connector	
<b>Environmental data</b>		
Ambient temp. (operation/storage)	-10°C ... +50°C/-20°C ... +60°C	
Protection class	IP 54	
Valid standards document	IEC 801	
Air humidity	max. 90% rel. humidity, non-condensing	
<b>Indicators</b>		
LED green	switch 1	
Display	—	LCD display – two lines with 16 characters each

## Description

The MA 4 or MA 4D is a connector unit for the bar code readers BCL 21/22 and BCL 31/32. It significantly simplifies both the electrical installation and the commissioning and maintenance of the respective BCL. In addition, it permits the networking of several bar code readers. The figure shows the combination of the connector unit and a BCL device.

The connector unit permits the storage of the current parameter set in the BCL into a non-volatile EEPROM to protect against power supply disruptions. This has the advantage that the BCL does not have to be reconfigured when it is exchanged. After plug-in, the parameters are loaded automatically into the BCL memory.

The MA 4D model also has a two-line display with 16 characters each for the display of parameters and operating values. According to your preferences, one or two results may be displayed. The various display modes are stored in the parameter set of the BCL.

All BCL 21/22 from software version 02.00 onwards or all BCL 31/32 with a PCB connector and a cable length of up to 3m may be used with the MA 4/MA 4D. The data are coded in the BCL identifier as follows:

### BCL 21/22 XYZ

The connector type is coded at the **X** location:

**X = 2:** LP connector

The length of the connection cable used is coded at the **Y** location:

**Y = 0:** 0,8 m connecting cable

**Y = 1:** 3m connecting cable

The BCL 31/32 is connected to the MA 4 or MA 4D via KB 031 3000.

## Order guide

	Type	Order code
Connector unit for BCL 21/22 and BCL 31/32 without display	MA 4	500 31537
Connector unit for BCL 21/22 and BCL 31/32 with display	MA 4D	500 31536

## Tables

### Remarks

When changing from BCL 21 or 31 to BCL 22 or 32, and vice versa, the scanner must be reset, e.g., with PC20. Detailed information can be found in the operating manual of the corresponding BCL.

The BCL must not be plugged in when the power is on.

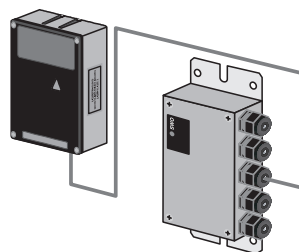

## MA 4/MA 4D

### Operating elements

#### Setting the network address

Rotary switch

position 0: operation with BCL 22 or BCL 32  
 position 1 to F: multiNet slave address  
 top: low address range 0 ... 15  
 bottom: high address range 16 ... 31

Jumper

#### Interface mode

DIP switch

SERV: service interface active / host interface deactivated  
 BETR: host interface active

#### Service connector

Sub-D connector, 9 pin

RS 232 interface for service/setup operation  
 standard data format: 9600 baud, 8 data bits, 1 stop bit, no parity  
 2=Rx/D, 3=Tx/D, 5=GND

#### Connector for BCL 21/22, BCL 31/32

PCB connector

connection for the BCL

#### RS 232 interface

Terminal 23

The RS232 interface is not floating.

Terminal 24

BCL 21 and BCL 31: RES,

BCL 22 and BCL 32: Rx/D

Terminals 5-6

BCL 21 and BCL 31: RES,

BCL 22 and BCL 32: Tx/D

BCL 22 and BCL 32: GND

#### RS 485 interface

Terminals 1-2

The RS 485 interface connections are implemented twice, for insertion.

Terminals 3-4

The RS 485 interface is not floating.

Terminals 5-6

RS 485A (line A)

RS 485B (line B)

RS 485 GND

#### Switching inputs

Terminal 7

BCL 21 and BCL 31 (one switching input): RES,

BCL 22 and BCL 32 (two switching inputs): SE2 – switching input 2, 12 ... 30VDC

Terminal 9

SE1 - switching input 1, 12 ... 30VDC

Terminal 11

VDD\_SE - supply voltage, switching input, equal to V\_IN device

Terminal 12

GND\_SE - supply voltage, switching input, equal to GND\_IN device

12 ... 30VDC switching input asymmetric to GND

#### Switching outputs

Terminal 13

BCL 21 and BCL 31 (one switching output): RES,

BCL 22 and BCL 32 (two switching outputs): SA2 – switching output 2

Terminal 14

SA1 - switching output 1

Terminal 16

GND\_SA – external supply voltage switching output 0VDC

Load must be connected asymmetrically to GND.

The switching voltage for the output is generated by the operating voltage V\_IN:

VDD\_SA = VDD\_IN

GND\_SA = GND\_IN

#### Operating voltage

Terminals 17-18

Connection terminals for the operating voltage of the MA 4 (10 ... 30VDC) and for the BCL used.  
 Dual design of the voltage supply connections for insertion or for the supply of further components.

Terminals 19-20

**Attention! PE must be connected for protection against faults!**

Terminals 21-22

V\_IN operating voltage 10 ... 30VDC

GND\_IN operating voltage 0VDC

PE protective earth, grounding

### Circuitry of the connector unit

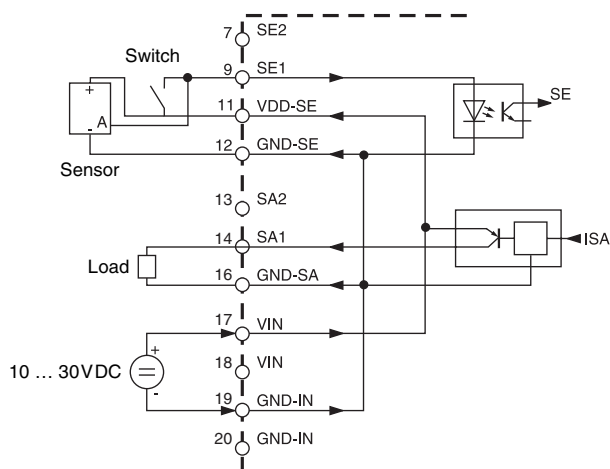

## Indicators

A LED labelled "SWO" is located on top of the connector unit. It indicates the state of the switching output 1. In addition, the MA 4D features the 2 x 16-character LCD display.

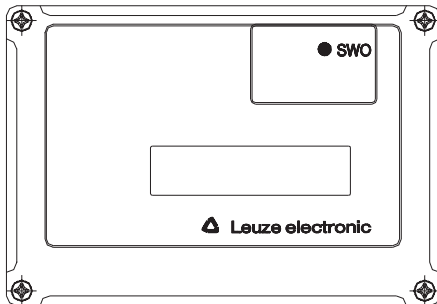

In the standard setting, the LED indicates the decoding of a bar code.

Please refer to the Technical Description BCL 21/22 or BCL 31/32 for further states of the switching output.

## Operating the MA 4D LCD display

If the LCD display is configured and ready for operation, the required information such as data read, software version, or status displays is shown automatically.

### Format

The configuration of the LCD display is possible for BCL 21/22 from version 2.0 onwards and for BCL 31/32.

The LCD display contains two lines with 16 characters each. There are 3 display modes:

1. Single line:  
a result is output in one line. If the information is longer than 16 characters, the characters > 16 are cut off. This means that two results may be output on the LCD display.
2. Double line:  
a result is displayed over both lines. Thus, only one result is visible in the display.
3. Depending on the size:  
if a result is > 16 characters, both lines are used  
if a result is < 16 characters, one line is used and two results are displayed

Address	Size	Designation	Range of values	Standard
161	byte	lcd_output_format	1: single line (two results) 2: double line (one result) 0: depending on the size	2: double line (one result visible)

The input can be specified as a PT commentary or in the BCL Config parameter list, e.g., PT0001610x.

### Text output

If a text from the controller is to be output to the MA 4D, the following command must be used. The text is output in the preselected line format.

Command: **M[Text]**

e.g.: if the text "input" is to be output to the LCD display, the command is: **Minput**